

HTP068

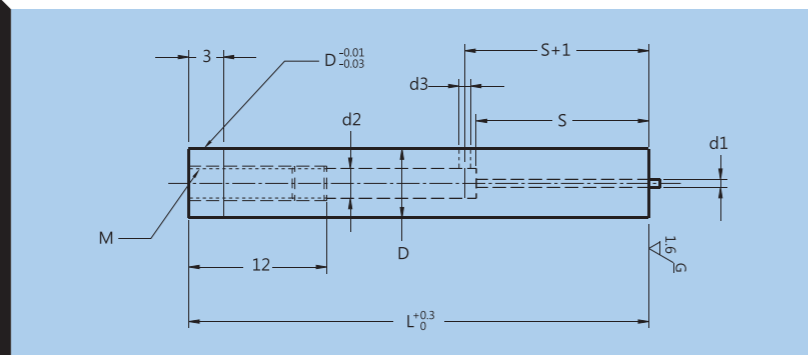

Type 品名	Material 材質	Hardness 硬度	Delivery 交貨日
HTP068	Equivalent to SKD11 SKD11同級	60~63HRC	8 Working Days 8個工作日

D Tolerance 柄部直徑公差	
a	m5
b	+0.005 0

Type 品名	D	L (u:10mm)	Jector pin diameter 頂出銷直徑	d1 hole dia 孔徑	d2	d3	S	M
HTP068	6	(40)~80	0.65	0.7	2.6	1.0	20	3
	8	(40)~100	1.0	1.1	3.4	1.5	27	4
	10	(40)~100	1.4	1.5	4.4	1.5	28	5
	13	(40)~100	1.7	1.8	4.4	1.5	28	6
	16	(40)(50)~100	2.7	2.8	4.4	1.5	36	6
	20	(40)(50)~100	2.7	2.8	4.4	1.5	36	6
	25	(40)(50)~100	2.7	2.8	4.4	1.5	36	6

\* L(40) → øD6~13=S15  
øD16~25=S17

\* L(50) → øD16~25=S24

Order Ex. 訂購範例

HTP068-6-L-□

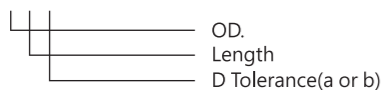

外徑  
長度  
柄部直徑公差(a or b)

Alterations 追加加工名稱	Description 加工說明	Order Ex. 訂購範例
LC	Length change 長度變更 30 ≤ LC < L *0.1mm increments 指定單位0.1mm	HTP068-6-40-a-LC
LKC LKZ	Full length tolerance change 變更全長公差 LKC → L $\begin{matrix} +0.3 \\ 0 \end{matrix}$ → $\begin{matrix} +0.05 \\ 0 \end{matrix}$ LKZ → L $\begin{matrix} +0.3 \\ 0 \end{matrix}$ → $\begin{matrix} +0.01 \\ 0 \end{matrix}$	HTP068-6-40-a-LKC
KC	Addition of single key flat to head 頭緣部止迴1面加工	HTP068-6-40-a-KC
WKC	Addition of double key flats in parallel 頭緣平行加工(2面)	HTP068-6-40-a-WKC
NC	The jector pin is removed. 拔除頂出銷 * Cannot be combined with AC 不可與AC併用	HTP068-6-40-a-NC