

HTP054

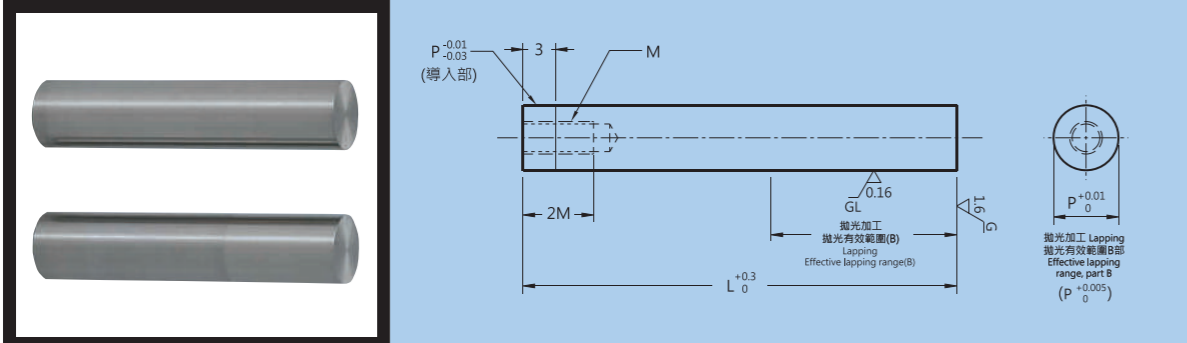

Type 品名	Material 材質	Hardness 硬度	Surface Treatment 表面處理	Delivery 交貨日
HTP054-A	Equivalent to SKD11 SKD11同級	60~63HRC	-	8 Working Days 8 個工作日
HTP054-B			Lapping 拋光加工	

Effective lapping range 拋光有效範圍	
P	(B)
6.000~9.999	19
10.000~	25

* If $L < (B) + 20$, (B) is adjusted to $(L-20)$.
 $L < (B) + 20$ 時, (B) 為 $L-20$

Type 品名	No.	L	(u:0.01mm) min. P max. (拋光加工為0.001mm單位 0.001mm increments for lapping)	M
HTP054-A HTP054-B	8	40/50/60/70/80/90/100	6.00~8.00	3
	10	40/50/60/70/80/90/100	8.01~10.00	4
	13	40/50/60/70/80/90/100	10.01~13.00	6
	16	40/50/60/70/80/90/100	13.01~16.00	6
	20	40/50/60/70/80/90/100	16.01~20.00	6
	25	40/50/60/70/80/90/100	20.01~25.00	6

Order Ex. 訂購範例

HTP054-□-8-L-P
 □ A or B
 8 No.
 L Length
 P OD.

沖頭材質
 加工材料尺寸
 長度
 外徑

Alterations	追加工名稱	Description	加工說明	Alterations	追加工名稱	Description	加工說明
Alterations to Tip 刃口追加工	PRC		Rounding of tip side edge 刃口側端面R加工	Alterations to Full Length 全長追加工	LC		Full length change 變更全長 *請參考表16
	PCC		Chamfering to tip side edge 刃口側端面C倒角加工		LKC LKZ		Full length tolerance change 變更全長公差
Others 其他	GC		Tapper machining of the pin tip 錐度加工	Others 其他	KC WKC		Addition of key flats 止迴加工
	PKC		Tip tolerance change 變更刃口公差		NDC		No press-in lead 無導入部

*追加工詳細說明請參考產品概要-追加工說明