

HTP013

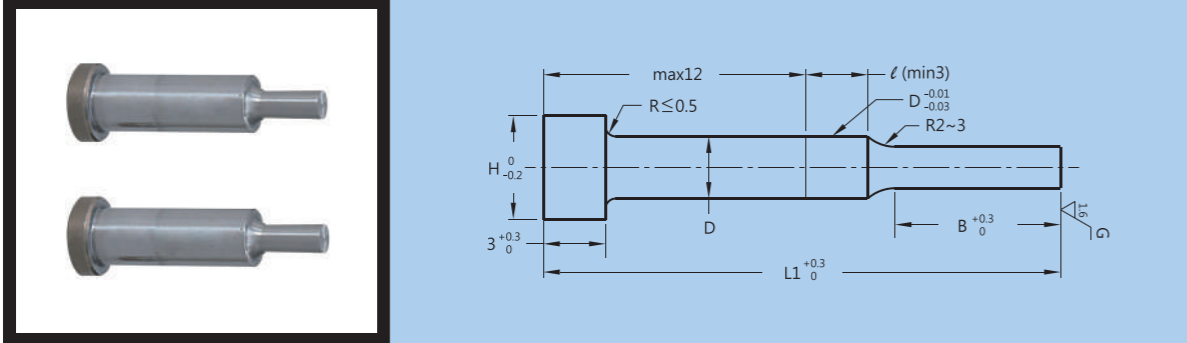

Type 品名	Material 材質	Hardness 硬度	Surface Treatment 表面處理	Delivery 交貨日
HTP013-A	Equivalent to SKD11 SKD11同級	60~63HRC	-	8 Working Days 8 個工作日
HTP013-B	SKH51	61~64HRC	-	
HTP013-C			TiCN Coating 3000HV	
HTP013-D	Powdered Highspeed Steel 粉末高速鋼	64~67HRC	-	
HTP013-E			TiCN Coating 3000HV	

**D Tolerance**  
柄部直徑公差

a	m5
b	+0.005 0

\* If  $W < 3$  for shapes III/IV, R13 is selected.  
III/IV形狀的 $W < 3$ 時會成為R13

\* The tip end of a TiCN coating punch is ground before the coating is applied.  
TiCN被覆處理品刃口端面的研磨是在被覆前進行

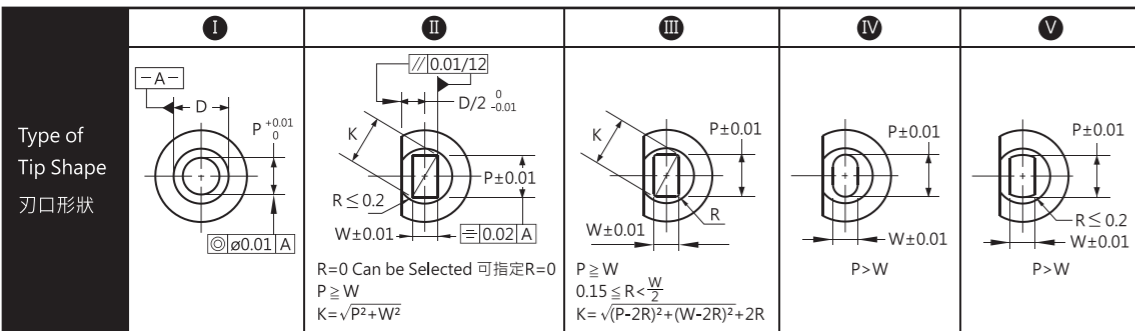

Type 品名	Tip Length 刃口長度	D	L1 (u: 10mm)	I (u:0.01mm) min. P max.	II/III/IV/V (u:0.01mm) P·Kmax.	II/III/IV/V (u:0.01mm) P·Wmin.	III (u:0.01mm) R	B	H	
HTP013-A HTP013-B HTP013-C HTP013-D HTP013-E	S	3	25~40	1.00~2.99	2.95	1.00	$0.15 \leq R < \frac{W}{2}$	8	5	
		4		2.00~3.99	3.95	1.20			7	
		5		2.00~4.99	4.95	1.20			8	
		6		2.50~5.99	5.95	1.50			9	
		8		5.00~7.99	7.95	2.00			11	
10	7.00~9.99	9.95	2.50	13						
HTP013-A HTP013-B HTP013-C HTP013-D HTP013-E	L	3	30~40	1.00~2.99	2.95	1.00		$0.15 \leq R < \frac{W}{2}$	13	5
		4		2.00~3.99	3.95	1.20				7
		5		2.00~4.99	4.95	1.20				8
		6		2.50~5.99	5.95	1.50				9
		8		5.00~7.99	7.95	2.00	11			
10	7.00~9.99	9.95	2.50	13						

\* I :  $P > D - 0.03 \rightarrow l = 0$   
If  $P > D - 0.03$  for a round punch,  
 $D_{-0.03}^{-0.01}$  (press-in lead) is not included.  
圓沖頭 $P > D - 0.03$ 時 ·  
不附 $D_{-0.03}^{-0.01}$  (導入部)

Order Ex. 訂購範例

HTP013-□-3-L1-P-W-□-□-□

- A B C D or E
- OD.
- Length
- Tip OD.
- Tip Wide(II/III/IV/V)
- D Tolerance(a or b)
- Tip Length(S/L)
- Type of Tip Shape(I/II/III/IV/V)

- 材質及表面處理方式
- 外徑
- 長度
- 前端外徑
- 前端寬度(II/III/IV/V)
- 柄部直徑公差(a or b)
- 刃口長度(S/L)
- 刃口形狀(I/II/III/IV/V)

Alterations	追加工名稱	Description	加工說明	Alterations	追加工名稱	Description	加工說明
Alterations to Tip 刃口追加工	Alterations to Full Length 全長追加工	PC	Tip dimension change 變更刃口尺寸 *請參考表9	LCT LMT	Changes to head thickness tolerance and full length are processed using a single code. 變更頭緣厚度公差與全長 *請參考表1		
		BC	Tip length change 變更刃口長度 *請參考表5	LKC LKZ	Full length tolerance change 變更全長公差		
		SC	Lapping of tip 刃口拋光加工 *請參考表1	KC WKC KFC NKC	Addition key flats 止迴加工		
		PRC	Rounding of tip side edge 刃口側端面R加工	HC	Head diameter change 變更頭緣直徑 *請參考表1		
	Alterations to Head 頭緣部追加工	PCC	Chamfering to tip side edge 刃口側端面C倒角加工	TC	Head thickness change 變更頭緣厚度 *請參考表1		
		GC	Tapper machining of the pin tip 錐度加工 *請參考表1	TKC TKM	Head thickness tolerance change 變更頭緣厚度公差		
		PKC	Tip tolerance change 變更刃口公差	TCC	Chamfering of head 頭緣部C面加工		
		Alterations to Shank 柄部追加工	Alterations to Full Length 全長追加工	LC	Full length change 變更全長 *請參考表3	SKC	Single key flat on shank 柄部平面加工(1面)
NDC	No press-in lead 無導入部						

\*追加工詳細說明請參考產品概要-追加工說明