

HFP063

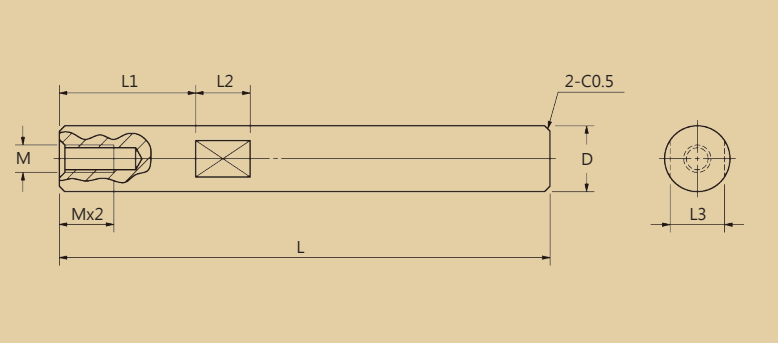

Type 品名	Material 材質	Surface Treatment 表面處理	Delivery 交貨日
HFP063-A	S45C 中碳鋼	Blackening 染黑	8 Working Days 8 個工作日
HFP063-B		Nickel Electroless 鍍無電解鍍	
HFP063-C	SUS304 不鏽鋼	-	

Choose Tolerance of Outsize Diameter 選擇外徑公差			
	I	II	III
D	h9	h7	g6
6	0 -0.030	0 -0.012	-0.004 -0.012
8~10	0 -0.036	0 -0.015	-0.005 -0.014
12~18	0 -0.043	0 -0.018	-0.006 -0.017
20~30	0 -0.052	0 -0.021	-0.007 -0.020
35~50	0 -0.062	0 -0.025	-0.009 -0.025

Tolerance of Length 長度公差	
L	TOL.
2~6	±0.1
7~30	±0.2
31~120	±0.3
121~400	±0.5
401~800	±0.8

Type	D	L(u:0.1mm)	M(粗螺紋)	L1(u:1mm)	L2	L3
HFP063-A	6	20.0~300.0	3/4	L1+L2≤L, L1=0或L1≥1	8	5
	8	20.0~400.0	3/4/5/6	L1+L2≤L, L1=0或L1≥1	8	7
	10	20.0~500.0	4/5/6	L1+L2≤L, L1=0或L1≥1	8	8
HFP063-B	12	30.0~600.0	5/6/8	L1+L2≤L, L1=0或L1≥1	10	10
HFP063-C	15	30.0~700.0	5/6/8/10	L1+L2≤L, L1=0或L1≥1	10	13
	20	40.0~800.0	5/6/8/10/12/16	L1+L2≤L, L1=0或L1≥1	10	17
	25	50.0~800.0	5/6/8/10/12/16	L1+L2≤L, L1=0或L1≥1	10	22
	30	60.0~800.0	8/10/12/16/20	L1+L2≤L, L1=0或L1≥1	15	27
	35	70.0~800.0	8/10/12/16/20/24	L1+L2≤L, L1=0或L1≥1	15	30

Order Ex. 訂購範例

HFP063-□-6-L-M-L1-□

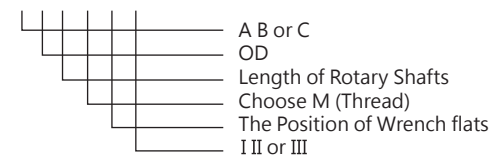

選擇材質
外徑尺寸
選擇旋轉軸長度
選擇螺紋M
扳手槽位置
選擇公差

Alterations	追加加工名稱	Description 加工說明	Order Ex. 訂購範例
A		Length tolerance change 長度公差變更	HFP063-A-6-100-M3-10-I-A(±0.03) Length tolerance change to ±0.03 長度公差變更為±0.03
C		Adds set screw flat 單平面或雙平面加工	HFP063-A-6-100-M3-10-I-C or 2C Adds set screw flats at one or two locations 單平面或雙平面追加
F		Adds key grooves 單鍵槽或雙鍵槽加工	HFP063-A-6-100-M3-10-I-F or 2F Key grooves at one or two locations 單鍵槽或雙鍵槽加工
M		Slit cam grooves 開縫凸輪用溝槽加工	HFP063-A-6-100-M3-10-I-M Slit cam grooves 開縫凸輪用溝槽加工
N		Adds ring grooves 扣環槽追加加工	HFP063-A-6-100-M3-10-I-N Adds ring grooves 扣環槽追加加工