

Set Collars with Setscrew-Smaller Type

固定環-止迴螺絲固定-精巧型

HFB022

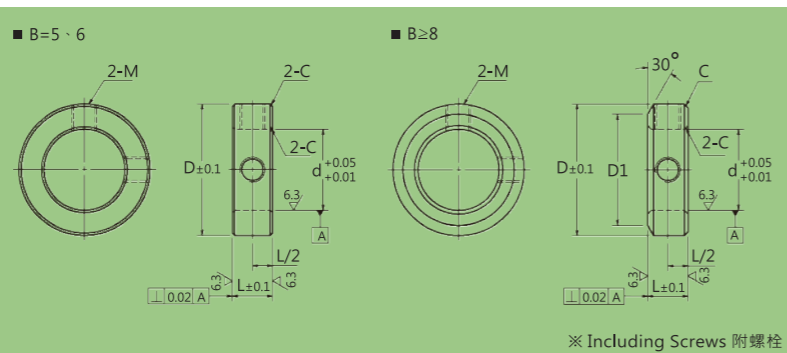

Type 品名	Material 材質	Surface Treatment 表面處理	Delivery 交貨日
HFB022-A	S45C 中碳鋼	Blackening 染黑	7 Working Days 7 個工作日
HFB022-B		Nickel Electroless 鍍無電解鍍	
HFB022-C	SUS304 不鏽鋼	-	

Type	d	L	D	D1	C	Screw 螺絲規格
HFB022-A HFB022-B HFB022-C	3	5	7	-	0.2	M3X3
	4	5	8	-	0.2	M3X3
	5	5	11	-	0.2	M3X3
	6	5	12	-	0.2	M3X3
	8	5	14	-	0.2	M3X3
	10	5	16	-	0.2	M3X3
	12	5	19	-	0.5	M3X3
	13	5	20	-	0.5	M3X3
	15	5	22	-	0.5	M3X3
	20	6	27	-	0.5	M4X3
	20	8	27	22.5	0.5	M4X3
	25	8	32	27.5	0.5	M4X3
	25	10	32	27.5	0.5	M4X3
	30	10	39	32.5	1	M5X4
	30	12	41	32.5	1	M6X5
	35	10	44	37.5	1	M5X4
35	12	46	37.5	1	M6X5	
40	15	51	42.5	1	M5X4	
40	18	53	42.5	1	M6X5	

Order Ex. 訂購範例

HFB022-□-3-L



選擇材質和表面處理方式
內徑尺寸
選擇固定環長度

※ u=unit

Set Collars with Slit-Standard Type

固定環-止迴螺絲固定-精巧型

HFB023

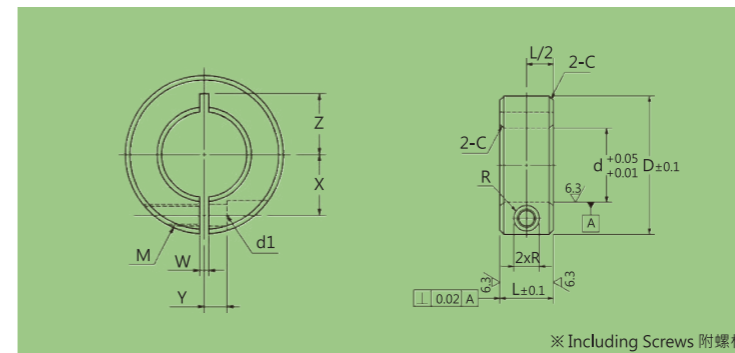

Type 品名	Material 材質	Surface Treatment 表面處理	Delivery 交貨日
HFB023-A	S45C 中碳鋼	Blackening 染黑	7 Working Days 7 個工作日
HFB023-B		Nickel Electroless 鍍無電解鍍	
HFB023-C	SUS304 不鏽鋼	-	

Type	d	L	D	M	d1	R	W	X	Y	Z
HFB023-A HFB023-B HFB023-C	3	8	16	M3	3.4	3	1	4.5	2.2	3~5
	4	8	18	M3	3.4	3	1	5	3	3.5~6
	5	8	20	M3	3.4	3	1	5.5	4	5~6.5
	5	10	22	M4	4.5	3.75	1	6.5	4	6~7
	6	8	20	M3	3.4	3	1	6	4	6~6.5
	6	10	20	M4	4.5	3.75	1	6	4	6~6.5
	8	8	25	M3	3.4	3	1.5	8	5	7~9
	8	10	25	M4	4.5	3.75	1.5	8	5	7~9
	8	12	30	M5	5.5	4.5	1.5	9	5	7~10
	8	15	30	M6	6.6	6	1.5	9	5	7~10
	10	8	30	M3	3.4	3	1.5	9	5	8~10
	10	10	30	M4	4.5	3.75	1.5	9	5	8~10
	10	12	30	M5	5.5	4.5	1.5	10	5	8~10
	10	15	35	M6	6.6	6	1.5	10	6	8~12
	12	8	30	M3	3.4	3	1.5	10	5	9~10
	12	10	30	M4	4.5	3.75	1.5	10	5	9~10
	12	12	30	M5	5.5	4.5	1.5	10	5	9~10
	12	15	35	M6	6.6	6	1.5	11	6	9~12
	13	10	30	M4	4.5	3.75	1.5	10	5	10
	13	12	34	M5	5.5	4.5	1.5	11	5	10~12
	13	15	35	M6	6.6	6	1.5	11	6	10~12
	15	10	34	M4	4.5	3.75	1.5	11.5	6	10~11
	15	12	35	M5	5.5	4.5	1.5	12	6	11~13
	15	15	40	M6	6.6	6	1.5	13	8	11~13
16	10	35	M5	5.5	4.5	1.5	12	6	11~12	
16	12	35	M5	5.5	4.5	1.5	12	6	11~12	
16	15	40	M6	6.6	6	1.5	13	8	11~13	
18	10	40	M5	5.5	4.5	1.5	14	7	13	
18	12	40	M5	5.5	4.5	1.5	14	7	13	
18	15	45	M6	6.6	6	1.5	15	8	13~15	

※ u=unit

Type	d	L	D	M	d1	R	W	X	Y	Z
HFB023-A HFB023-B HFB023-C	20	10	40	M5	5.5	4.5	1.5	14	7	13
	20	12	40	M5	5.5	4.5	1.5	14	7	13
	20	15	45	M6	6.6	6	1.5	15	8	13~15
	20	20	45	M6	6.6	6	1.5	16	8	13~15
	25	12	45	M5	5.5	4.5	1.5	17	7	16
	25	15	50	M6	6.6	6	1.5	18	10	16~18
	25	20	55	M6	6.6	6	1.5	20	10	16~20
	30	15	55	M6	6.6	6	1.5	20	10	18~20
	30	20	60	M8	9	7	1.5	23	10	18~21
	35	15	60	M6	6.6	6	2	23	12	21
	40	18	70	M8	9	7	2	26	13	23
	50	22	85	M10	11	9	3	32	16	28
60	22	95	M10	11	9	3	37	18	-	
80	32	130	M16	18	13	5	50	22	-	
100	36	150	M16	18	13	5	60	26	-	

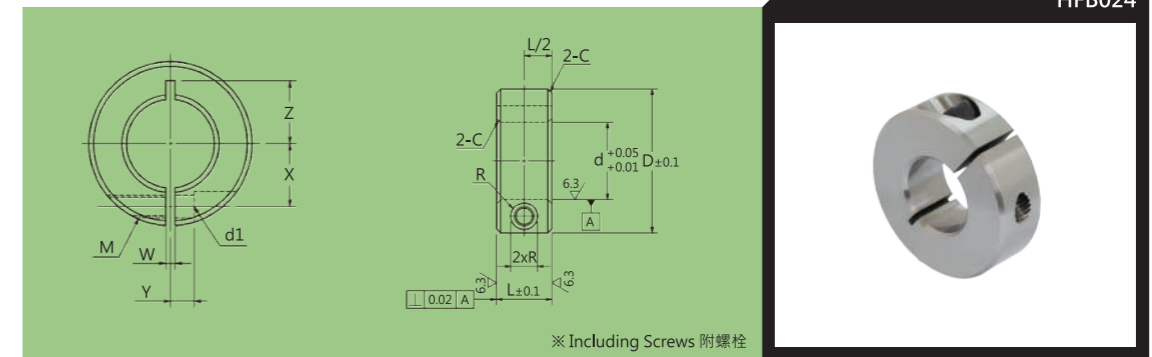

HFB024

※ Including Screws 附螺柱

Order Ex. 訂購範例

HFB023-□-3-L

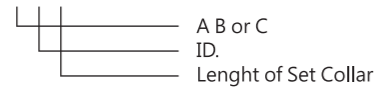

選擇材質和表面處理方式
內徑尺寸
選擇固定環長度

Type 品名	Material 材質	Surface Treatment 表面處理	Delivery 交貨日
HFB024-A	Aluminium 鋁合金	-	7 Working Days 7 個工作日
HFB024-B		Anodizing 白色陽極	
HFB024-C		Black Anodizing 黑色陽極	

Type	d	L	D	M	d1	R	W	X	Y	Z
HFB024-A HFB024-B HFB024-C	3	8	16	M3	3.4	3	1	4.5	2.2	3
	4	8	18	M3	3.4	3	1	5	3	3.5
	5	8	20	M3	3.4	3	1	5.5	4	5
	6	8	20	M3	3.4	3	1	6	4	6
	8	8	25	M3	3.4	3	1.5	7	5	7
	8	10	25	M3	3.4	3	1.5	7	5	7
	10	10	30	M4	4.5	3.75	1.5	9	5	8
	12	10	30	M4	4.5	3.75	1.5	10	5	9
	13	10	30	M4	4.5	3.75	1.5	10	5	10
	15	10	34	M4	4.5	3.75	1.5	11.5	6	10
	16	10	35	M5	5.5	4.5	1.5	12	6	11
	16	12	35	M5	5.5	4.5	1.5	12	6	11
	20	10	40	M5	5.5	4.5	1.5	14	7	13
	20	12	40	M5	5.5	4.5	1.5	14	7	13
	20	15	40	M5	5.5	4.5	1.5	14	7	13
	25	12	45	M5	5.5	4.5	1.5	17	7	16
	25	15	45	M5	5.5	4.5	1.5	17	7	16
	30	15	55	M6	6.6	6	1.5	20	10	18
	35	15	60	M6	6.6	6	2	23	12	21
	40	18	70	M8	9	7	2	26	13	23
50	22	85	M10	11	9	3	32	16	28	

Order Ex. 訂購範例

HFB024-□-3-L

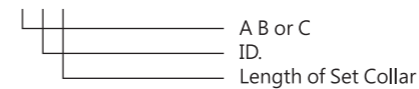

選擇材質和表面處理方式
內徑尺寸
選擇固定環長度